

Vinylcomfort FLOORING COLLECTION



Home

Commercial

Nature at your feet

WICANDERS®



Excellence in flooring



Amorim Revestimentos, a company of the Portuguese Amorim Group, with over 130 years of experience in selected cork products, has developed unique flooring and wall covering solutions throughout its history. Amorim Revestimentos sells its products in more than 51 countries and is known throughout the world as a pioneer in creating top-quality, ground-breaking solutions.

Reflecting a highly sustainable development, the Amorim Group developed a revolutionary process that is adapted to nature's rhythms. The first extraction of cork from the cork oak tree occurs only twenty-five years after planting, following which it is harvested in nine-year cycles, without ever damaging the tree in any way. This method allows the cork oak forest – montado - to fulfil its role of fixing CO₂, thus actively contributing to reduce global warming.

The regular extraction of cork is also a decisive contributor to sustainability: environmental (conserving biodiversity and preventing desertification), social (population settlement and jobs creation) and economic. The company's in-depth knowledge and respect for nature, its continuous investment in technological innovation and highly-specialised staff, have guaranteed its leading position in the international field. **Wicanders** has strengthened its existing cork products (**Corkcomfort**) and wood-on-cork products (**Woodcomfort**), by investing in new product lines such as vinyl (**Vinylcomfort**), linoleum (**Linocomfort**), and parquet (**Parquet**), towards a new phase marked by the evolution from a cork manufacturer to a flooring solutions company.

Cutting-edge technology, know-how, creativity and audacity are merged into an avant-garde approach inspired on nature's values.

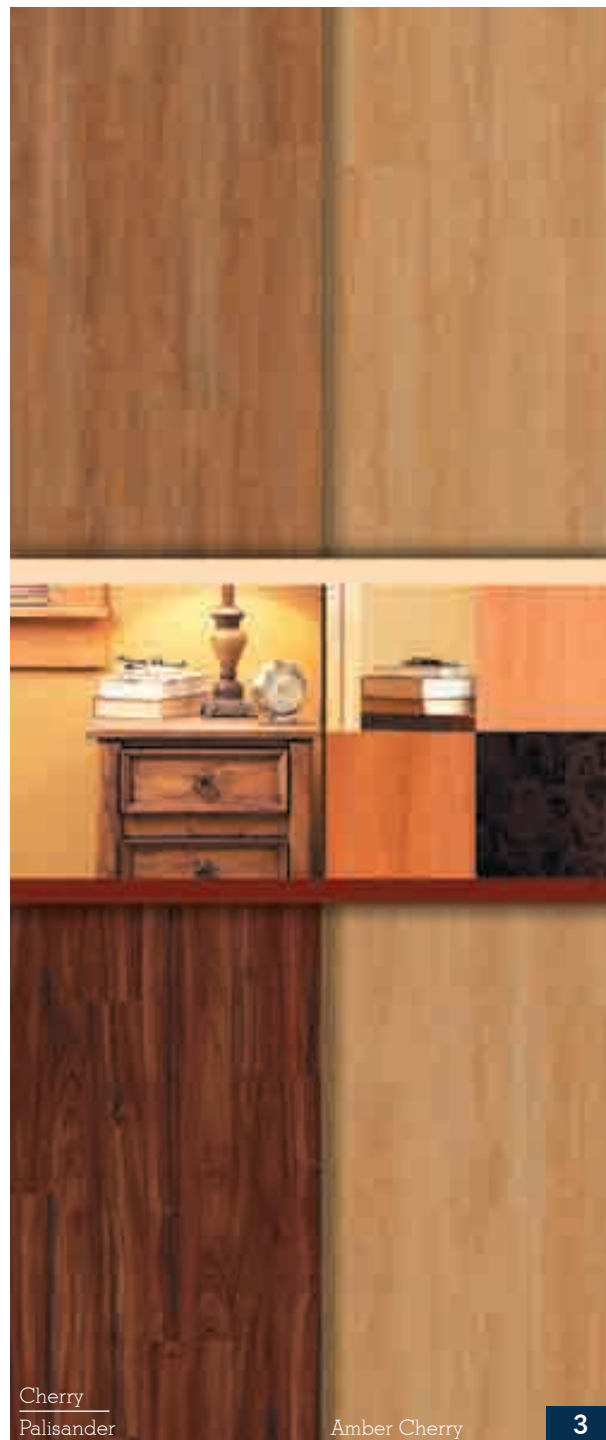

Cherry
Palisander

Amber Cherry



Setting **new standards** for flooring

As a result of advanced technological research, this new flooring for public and private areas has changed the way we envision spaces, suggesting a more liberating and inspiring experience.

Following the latest trends in flooring, **Vinylcomfort** is a new concept in Luxury Vinyl Tile (LVT) floating floors, surpassing existing glue-down floor solutions and other similar surfaces. Positioned as a forerunner in the vanguard of vinyl flooring for residential and commercial environments, **Vinylcomfort** combines a strong design element with the benefits of an innovative structure supported by a double cork layer. The new **Vinylcomfort** collection has revolutionized the range of avant-garde flooring solutions by perfectly interpreting the textures and patterns of noble hardwoods, exotic stones and innovative materials, offering numerous choices in the creation of comfortable and distinctive atmospheres, achieving a perfect match between sustainability and breakthrough solutions.



A new era for vinyl flooring

With solid technological know-how in developing cork-based flooring, **Wicanders** has innovated in the vinyl flooring market, presenting a pioneering product for home and commercial spaces.

Thanks to its unique characteristics, **Vinylcomfort** distinguishes from traditional glue-down LVT floors by presenting itself in a floating solution, being also superior to other existing vinyl floating solutions, due to a more advanced structure that incorporates an additional cork layer.

The natural characteristics of cork provide greater walking comfort, as well as improved acoustic properties. The double cork layer also plays a fundamental role in providing heat insulation, offering you unrivalled comfort with reduced energy costs, improving eco-efficiency.

Vinylcomfort's excellence is enhanced by the nobility of its visuals. Advanced techniques allowed the beauty and texture of various materials to be re-invented, resulting in a stylish collection. Furthermore, innovative features and dimensions, not available in similar competitor products, enriched even more this collection.

The advantages of this product are not limited to aesthetics, also inviting you to enjoy your time. Providing you with a fast and easy installation, it doesn't require a complex subfloor preparation or the use of adhesives that represent increased costs, time consumption and environmental harm.

From production to installation, **Vinylcomfort** stands out for its exceptional design and excellent performance.

Developed for homes, hotels, shops, offices and other locations where fashion, durability and cleanliness of the floor are decisive factors, this line exceeds all the expectations of interior designers, architects and builders. Surprising ambiances can be created at reasonable cost and within a short period of time. After installation, **Vinylcomfort** confirms its efficiency, ensuring many years of easy maintenance and proven resistance to wear and tear.



Cinder Oak

Auburn Oak



Explore our essence

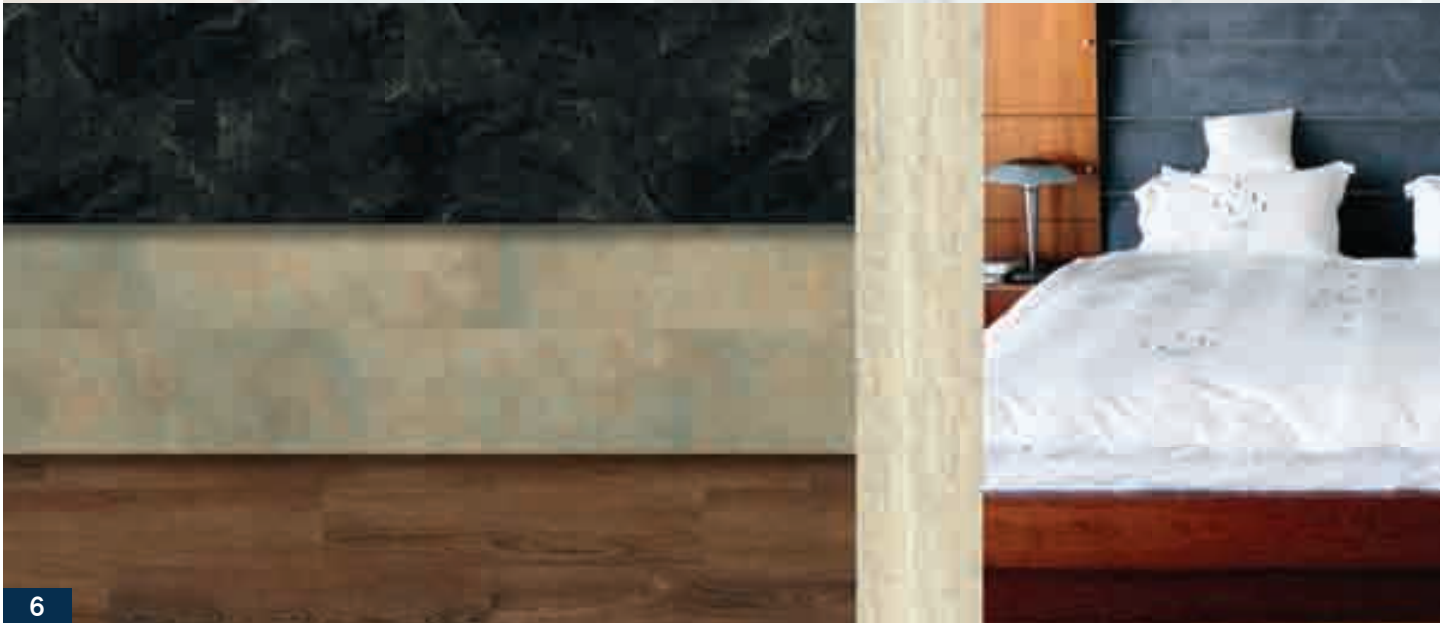

Your design for life

FEEL NATURAL

Natural and realistic effects

The matte surface, combined with a wide range of patterns, allows a true material interpretation with effects capable of inspiring unique sensations. The excellence of the visuals is reinforced by a wide range of dimensions available.

FEEL UNIQUE

Endless options

Architects and interior designers now have at their disposal a unique collection inspired by nature. Following the latest trends on diverse surfaces as wood, concrete, ceramics, aged metal or natural stone, **Vinylcomfort** exhibits genuine textures felt through a simple look. Create sophisticated or rustic ambiances in new or renovated spaces.

FEEL SAFE

A long-lasting surface

Extremely resistant to intense everyday wear and tear, **Vinylcomfort** is your floor for life, at home, shop or office.



Your wellbeing

FEEL RELAXED

Quiet environments

It is a well known fact that noise contributes to stress. Composed by a double cork layer, **Vinylcomfort** offers remarkable sound reduction, promoting a harmonious and relaxing environment.

FEEL WARM

Welcoming environments

The natural properties of cork play a fundamental role in providing heat insulation, offering you unrivalled comfort and hospitality with reduced energy costs. A benefit not only to your investment, but to your health as well.

FEEL COMFORTABLE

Comfort that walks alongside you

Vinylcomfort was designed to provide comfort in the most demanding environments. The double cork layer is soft enough to reduce the impact on your joints and back, allowing you to enjoy natural comfort in the simple act of walking.



Your time

FEEL POWERFUL

We create, you live

Vinylcomfort saves you time and money. Quick and easy to install, with the CORKLOC® system you are able to transform your environment without interfering with your day-to-day activities, and also profit from its re-use, if you wish to.

Commercial spaces can benefit from a complete overnight transformation with no need to close. It does not require adhesives or complex subfloor preparation. Furthermore, this product comes with an all around edge sealing for increased moisture protection.

FEEL FREE

Extra time in your day

Thanks to its easy maintenance, **Vinyl**comfort does not require any special care, providing you with the time and freedom to do what you really like. However, **Wicanders** offers you a complete care and maintenance system if needed. With a sophisticated look, high performance and durability, this is the floor that invites you to enjoy life.

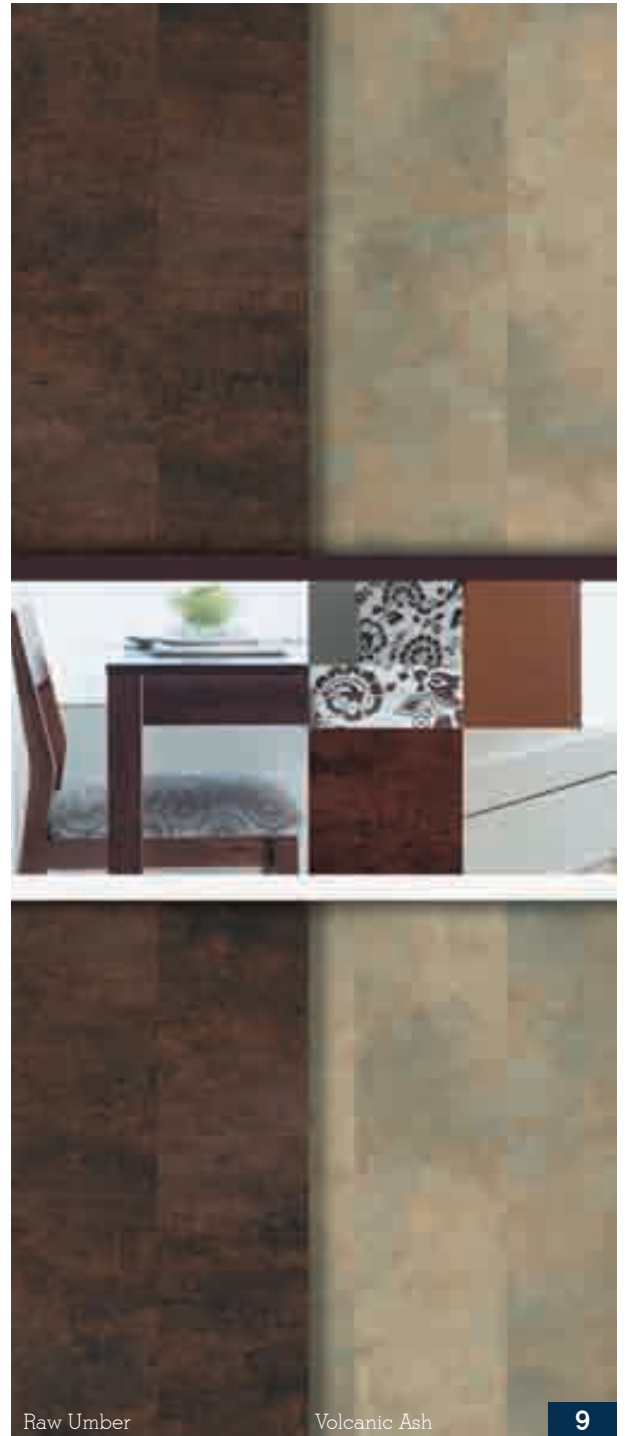

Raw Umber

Volcanic Ash

A revolutionary concept

Wicanders presents a cutting-edge product developed to meet your present expectations and future needs!

Wicanders is the first and only brand to offer a floating vinyl product with a double cork layer, allowing unique performance in what concerns thermal insulation, walking comfort and acoustical behavior (impact sound reduction and step sound).

Atmospheres full of character

Fell your essence in the room you create. See your personality brought to life through 14 unique references with advanced embossing features so that no detail goes unnoticed.

Vinylcomfort will enrich your space with charm and charisma.

Versatility

A floating product combining cork and vinyl, available in two formats conceived for a perfect recreation of the original materials:

905 x 295 x 10.5 mm – non-wood visuals

905 x 185 x 10.5 mm – wood visuals



Home



Commercial

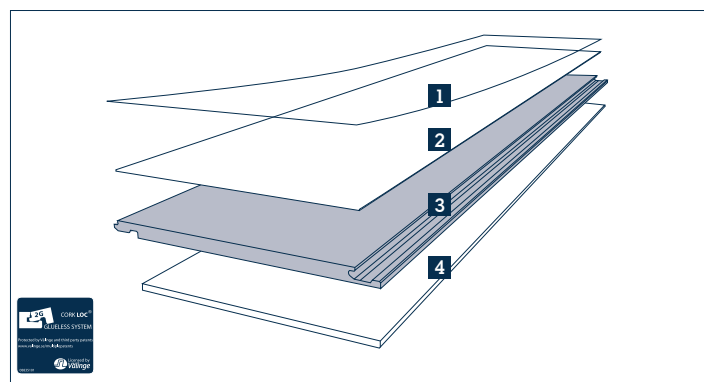

- 1.0 Vinyl sheet (with 0,3mm wear layer)
 - 2.0 High density cork core layer
 - 3.0 HDF – High Density Fibreboard with CORKLOC®
 - 4.0 Integrated insulating cork underlay
- All around edge sealing



Vinylcomfort visuals

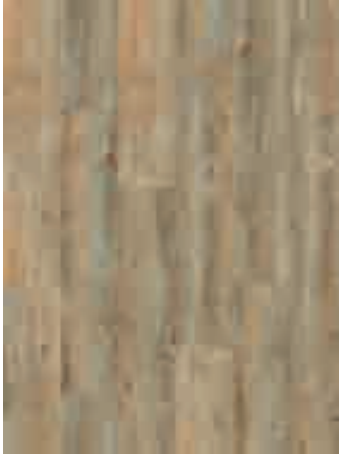

Alaska Oak

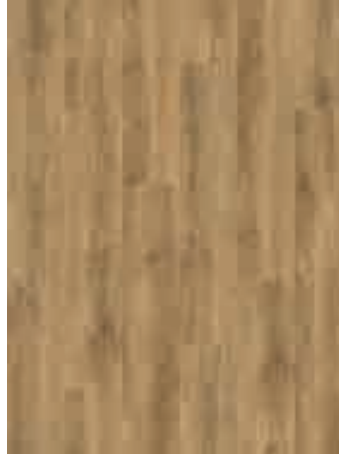

Chalk Oak



European Oak



Provence Oak



Canyon Oak



Smoked Oak



Amber Cherry



Cherry



American Walnut



Palisander



Bianco Travertine



Volcanic Ash

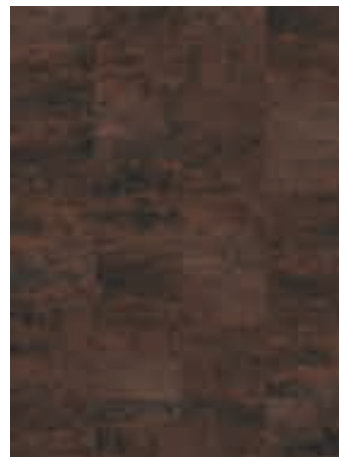

Raw Umber

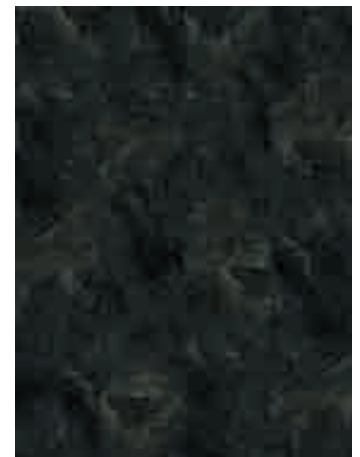

Coal Slate

Extra performance for the most demanding environments

To address the needs of demanding commercial spaces, **Wicanders** has developed a Commercial collection. With a 0,5mm wear layer, this product is suitable for heavy traffic areas until Class 33 (acc. EN685).

Unique designs for distinctive ambiances

Create inimitable design options for residential or commercial areas. **Wicanders** has created 14 exclusive visuals from noble wood species to exciting abstract designs.

The character of these visuals is emphasized by the micro-bevelled edges and refined embossing features.

Innovation

To respect the uniqueness of the visuals, new formats were selected:

605x445x10.5mm – non-wood visuals

1220x185x10.5mm – wood visuals

The resistance of the wear layer combined with a ceramic finish, allows us to give 25 years warranty for residential areas and 15 years for commercial areas until class 33.



Home



Commercial

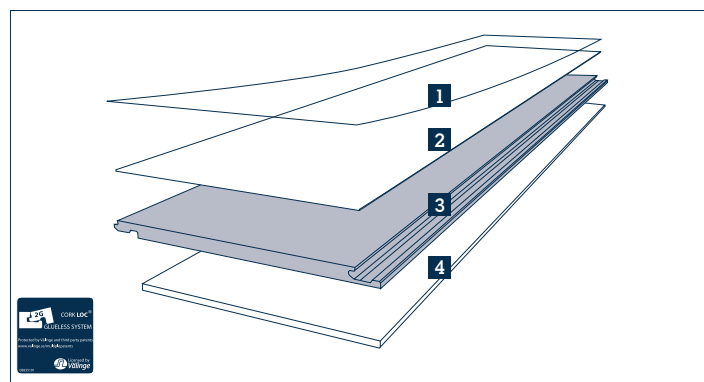

- 1.0 Vinyl sheet (with 0,5mm wear layer)
 - 2.0 High density cork core layer
 - 3.0 HDF – High Density Fibreboard with CORKLOC®
 - 4.0 Integrated insulating cork underlay
- All around edge sealing



Vinylcomfort visuals

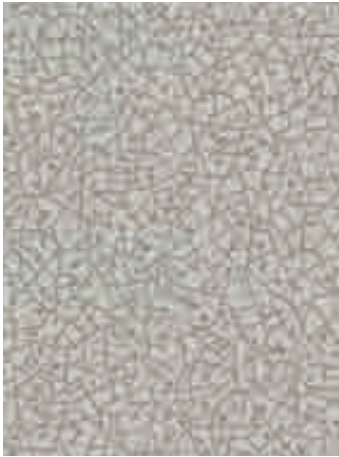

Steel Petal



Mystic Tweed



Pearl Petal



Midnight Tweed



Ebony Petal



Linen Cherry

COMMERCIAL
FLOORING
COLLECTION



Sand Oak



European Cherry



Wheat Pine



Elegant Oak



Auburn Oak

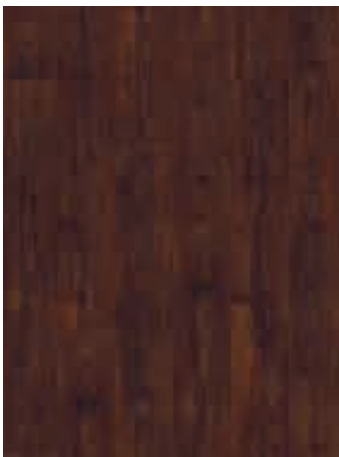

Tobacco Pine

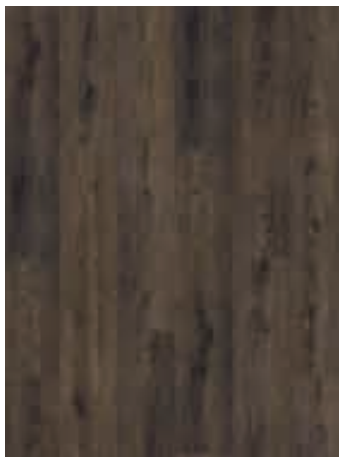

Cinder Oak



Exotic Cherry

Product selector





HOME FLOORING COLLECTION

Finishing		PU acrylate UV	
Thickness	mm	10,5	10,5
	inches	13/32	13/32
Dimension	mm	905x295	905x185
	Inches	35-5/8x11-5/8	35-5/8x7-9/32
Embossing		Yes	Yes
Bevelling		No	No
Reference			
Raw umber		B0O0001	
Coal Slate		B0O1001	
Bianco Travertine		B0O2001	
Volcanic Ash		B0O3001	
Alaska Oak			B0Q0001
Chalk Oak			B0Q1001
European Oak			B0Q2001
Provence Oak			B0Q3001
Canyon Oak			B0Q4001
Smoked Oak			B0Q5001
Cherry			B0Q6001
Amber Cherry			B0Q7001
Palisander			B0Q8001
American Walnut			B0Q9001

COMMERCIAL FLOORING COLLECTION

Finishing		Ceramic Finish	
Thickness	mm	10,5	10,5
	inches	13/32	13/32
Dimension	mm	605x445	1220x185
	Inches	23-13/16x17-4/8	48-1/32x7-9/32
Embossing		Yes	Yes
Bevelling		4 sides	4 sides
Reference			
Steel Petal		B0O4001	
Mystic Tweed		B0O5001	
Pearl Petal		B0O6001	
Midnight Tweed		B0O7001	
Ebony Petal		B0O8001	
Linen Cherry			B0R0001
Sand Oak			B0R1001
European Cherry			B0R2001
Wheat Pine			B0R3001
Elegant Oak			B0R4001
Auburn Oak			B0R5001
Tobacco Pine			B0R6001
Cinder Oak			B0R7001
Exotic Cherry			B0R8001

Technical Data Sheet

Test	Standard	Unit	Vinylcomfort PU acrylate UV	Vinylcomfort Ceramic
Level of use Domestic	EN 685	Class	23 	23 
Level of use Commercial	EN 685	Class	32 	33 
Level of use Industrial	EN 685	Class	----	----
General properties	EN 649 + EN 14085			
Dimensions	EN 427	mm	905x295x10,5 · 905x185x10,5	605x445x10,5 · 1220x185x10,5
		Inches	35-5/8x11-5/8x13/32 · 35-5/8x7-9/32x13/32	23-13/16x17-4/8x13/32 · 48-1/32x7-9/32x13/32
Wear layer thickness	EN 429	mm	0,30	0,50
Apparent density	EN 672	Kg/m ³	900	960
Mass per unit area	EN 430	g/m ²	9800	10150
Dimension stability	EN 669	%	Length: 0 / Width: 0,05	Length: 0,05 / Width: 0,07
Safety properties				
Fire resistance	EN13501-1	Class	Bfls1	Bfls1
Specific optical density	ASTM E662-3	Density	Non-flaming: 533,9 / Flaming: 356,6	----
Critical radiant flux	ASTM E648	W/cm ²	0,74	----
Surface flammability	ASTM D2859	Pass/fail	Passes	----
Sliding coefficient	EN 13893	Coeff.	DS	DS
	DIN 51130	Class	R-9	R-9
Additional properties				
Impact sound reduction	ISO 140-8	dB	16	16
Step sound	NF S 31 - 074	dB	81	81
Impact insulation class	ASTM E492-04	dB	59	59
Thermal resistance	EN 12667	m ² K/W	0,112	0,093
Thermal conductivity	EN 12667	W/mK	0,103	0,113
Wear resistance	EN 660-2	Nr. of rev./mass loss	2000 / 138,3 mgr.	5000 / 200 mgr.
Castor chair test	EN 425	Effect	no visible change / damages	no visible change / damages
Chair leg resistance	EN 424	Effect	no visible change / damages	no visible change / damages
Residual indentation	EN 433	mm	0,27	0,14
Electrostatic propensity	EN 1815	kV	PE foil: PVC: 2,5 Rubber: 2,1	PE foil: PVC: 1,5 Rubber: 0,4
			None: PVC: 2,0 Rubber: 1,6	None: PVC: 1,5 Rubber: 0,1
Electrical resistance	EN 1081	Ohm	Vertical: PE foil: 3x10 ¹⁰ none: 3x10 ¹⁰	Vertical: PE foil: 8x10 ⁹ none: 8x10 ⁹
			Horizontal: PE foil: 2x10 ¹¹ none: 1x10 ¹¹	Horizontal: PE foil: 2x10 ¹¹ none: 8x10 ¹⁰
Effect of stains	EN 423	Effect (a)	unchanged	unchanged
Chemical resistance (b)	ASTM F 925-02	Rate	Rate 0 (no observed effect)	----
Colour fastness	EN 15187	Blue wool scale	>6	6
Formaldehyde emission	DIN EN 717-1/2	Class	E1	E1
PCP (pentachlorophenol)	CEN/TR 14823 (Ihd-W 409)	mg/Kg	PCP free	PCP free
VOC loss	EN 664	%	2,1	2,2
Exudation of plasticisers	EN 665	Visual assessment	No staining	No staining

(a) The following products were tested: disinfectant, petroleum, spirit, C2H5OH, NH4OH, citric acid, iodine

(b) The following products were tested: White Vinegar (5% Acetic acid); Rubbing Alcohol (70% Isopropyl); Mineral Oil; 5% Sulfuric Acid; Household Bleach; Household Ammonia; Kerosene; Olive Oil; Unleaded Gasoline



AMORIM

Excellence in flooring

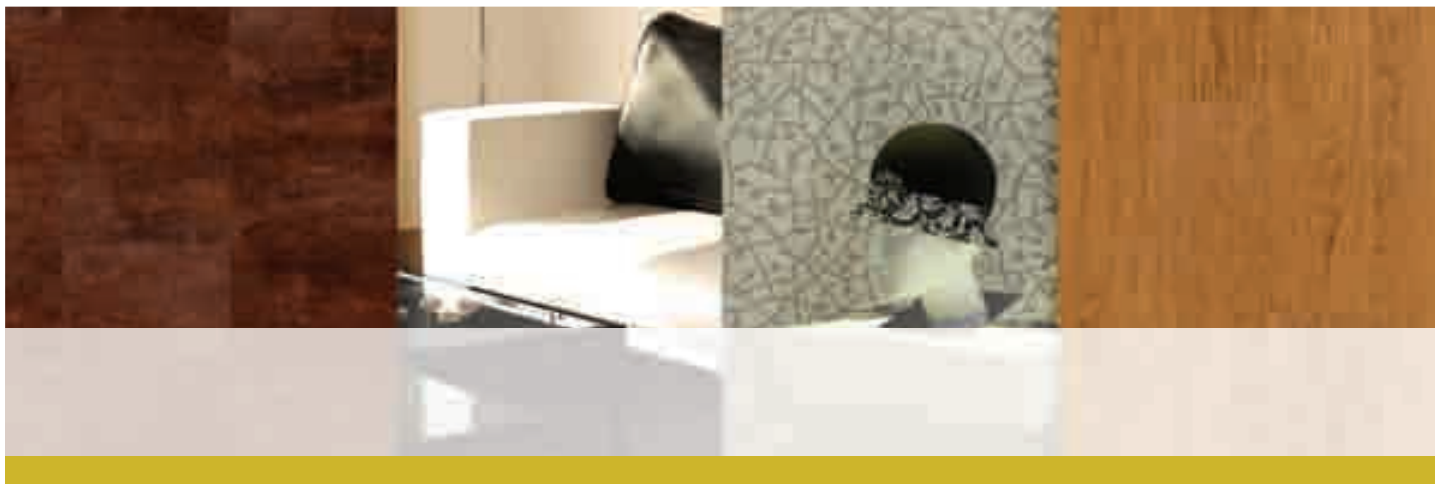

NL/BE/LU/FR Amorim Benelux B.V., +31 166 604 111 info.ar.nl@amorim.com

DE Amorim Deutschland GmbH, +49 4221 59 301 germany.ar.de@amorim.com

AT Amorim Flooring Austria, +43 1 545 16 51 0 austria.ar.de@amorim.com

CH Amorim Flooring (Switzerland) AG, +41 41 726 20 20 . info@amorim.ch

PT Amorim Revestimentos S.A., +351 22 747 5250 aid.ar@amorim.com

ES Amorim Revestimentos, S.A., +34 902 307 407 info.ar.es@amorim.com

CN Amorim Revestimentos - Beijing, +86 10 58672159 amorimre@macau.ctm.net

JP Amorim Japan Corporation, +81 50 1184 5995 otoiawase-ar@amorim.co.jp

DK/FI/NO/SE Amorim Flooring Nordic A/S, +45 44 681 900 mail@amorim-flooring.dk

PL Dom Korkowy, Sp. z o.o., +48 12 637 9639 krakow@domkorkowy.pl

US/CA Amorim Flooring North America, +1 410 553 6062 info.ar.us@amorim.com

Others Amorim Revestimentos, S.A., +351 22 747 5600 geral.ar@amorim.com

www.wicanders.com

